

2VRE5-1800TF

DATA SHEET



Tubular Flooded SOPzS Battery Cell

Discover® Tubular Flooded RE Series Batteries provide superior deep cycling performance and reliability for demanding commercial, industrial and residential applications. Discover® Tubular Flooded RE Series Batteries utilize Advanced Tubular Plate Technology to deliver long service life with low maintenance requirements. RE Series Batteries provide reliable energy storage for Stationary Backup and Telecom Networks, Road Surface, and Rail Traffic Signaling Systems, Solar, Wind, and Hybrid Off-grid and Grid-tie RE applications. Discover® Tubular Flooded RE Series batteries provide maximum efficiency per discharge cycle, and proven reliability in remote, high temperature, or unstable power network installations.

Mechanical Drawings

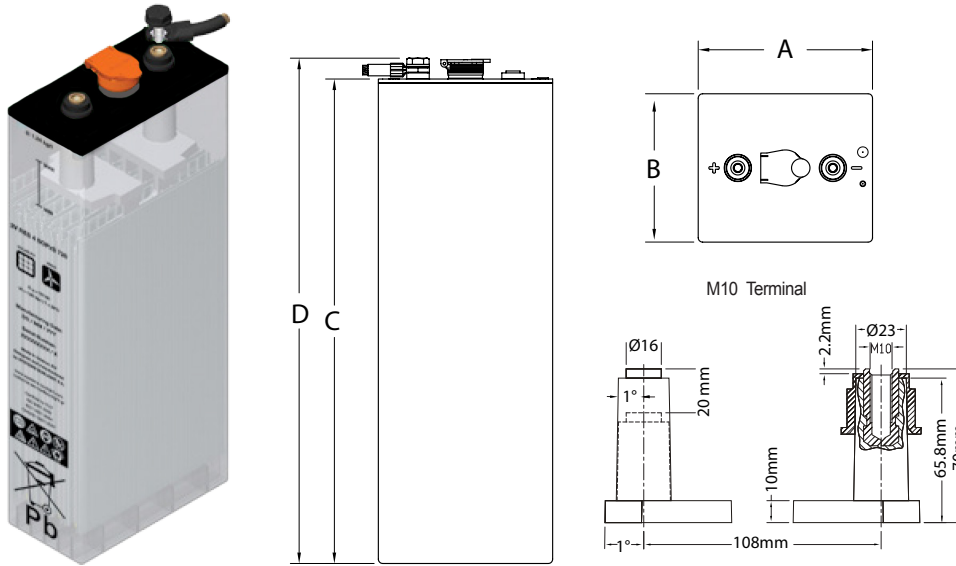

Mechanical Specifications

Industry Reference	2V Tubular Flooded SOPzS	
Length (A)	7.8 in	198 mm
Width (B)	4.7 in	119 mm
Height (C)	24.1 in	613 mm
Total Height (D)	25.2 in	640 mm
Weight (Wet)	82 lbs	37 kgs
Weight (Dry)	57 lbs	26 kgs
Terminal	M10 Insert	
Poles	2	
Cell(s)	1	
Container	Translucent Polypropylene	

Electrical Specifications

Reference LVD (I10 at 20°C 68°F)	20% DOD	2.03 V
	50% DOD	1.95 V
	80% DOD	1.90 V
Cycle Life	20% DOD	6000 cycles
	50% DOD	2300 cycles
	80% DOD	1500 cycles
RINT	0.52 mΩ	
Short Circuit (20°C 68°F)	3900 A	
Self Discharge (20°C 68°F)	2-3% per month	
Maximum Operating Temperature	-35°C -31°F - 50°C 122°F	
Electrolyte (20°C 68°F)	1.24 S.G.	

Electrical Specifications

1.85 VPC at 20°C 68°F				1.75 VPC at 27°C 80°F				1.75 VPC at 20°C 68°F			
240 HR	120 HR	120 HR	100 HR	20 HR	10 HR	8 HR	5 HR	3 HR	1 HR	1 HR	1 HR
936 AH	1.80 KWH	900 AH	880 AH	736 AH	661 AH	518 AH	575 AH	479 AH	0.66 KWH	332 AH	

Constant Power Reference in Watts / Cell to 1.92VPC at 20°C | 68°F

240 HR	168 HR	120 HR	100 HR	72 HR	50 HR	48 HR	24 HR	20 HR	12 HR	10 HR
-	-	-	-	-	-	-	-	-	-	-

Benefits & Features

Unparalleled Performance

- Engineered to deliver 80% of rated capacity above 1.90 volts.

Long Cycle Life

- Tubular positive plates and proprietary alloy compositions to provide a 50% DoD cycle life of up to 2300 cycles @ 20°C / 68°F.

Low Total Cost of Ownership

- Low cost per cycle. Lifetime value maximized especially in hybrid systems where using batteries can dramatically reduce generator run times delivering lower maintenance and fuel costs and less CO2 emissions.

Low Maintenance

- Low maintenance designs, clear case jars and available watering systems to ease electrolyte level maintenance.

Complete Battery Solution

- Complete and ready to install systems, filled and charged with all necessary installation accessories (available Dry Charged).

Safe

- Tested and verified for compliance to applicable International Safety Standards. Built-in Ceramic flame arrestors to guard against ignition risks.

IEC 61427 Compliant

- Tested for compliance with the International Electrical Commission requirements for battery performance and life in PV applications.

Certified Quality

Discover Energy Corp. and its facilities and products are certified to multiple standards and compliance:

- IEC 61427: Requirements for Photovoltaic Energy Systems
- IEC 60896-11: Requirements for vented lead-acid batteries
- DIN 40736-1: Specifications for RE Series Cells
- DIN 40737-3: Specifications for RE Series Blocks
- EN 50272-2: Safety Requirements for Stationary batteries
- ISO 9001, ISO 14001, BS OHSAS 180:
- Manufacturing and Production facilities.
- ETTS Germany



Contact Us



Unit 5-13511 Crestwood Place,
Richmond, BC, V6V 2E9, Canada
Email: info@discover-energy.com
www.discover-energy.com

Expected Service Life vs. Operating Temperature

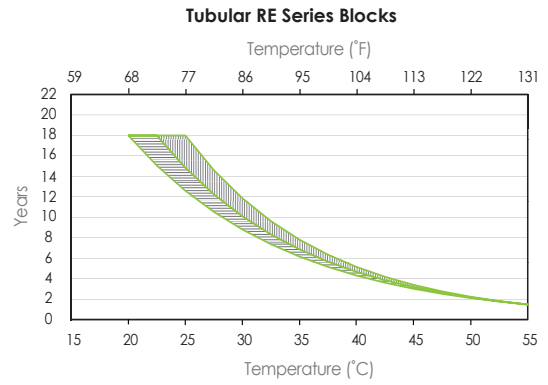
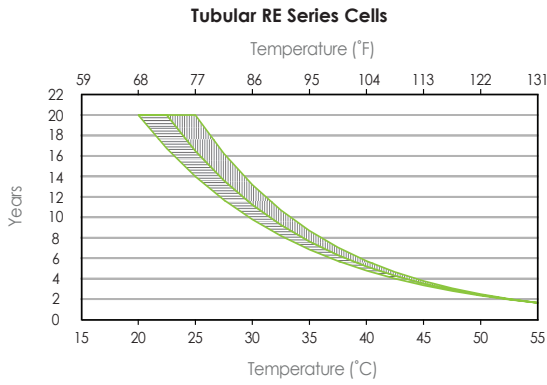

Self-Discharge Characteristics

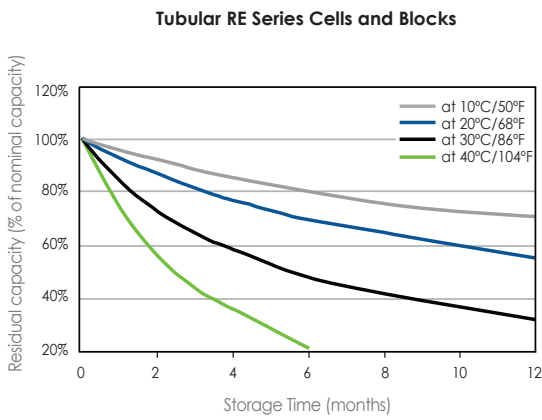

Capacity vs. Temperature

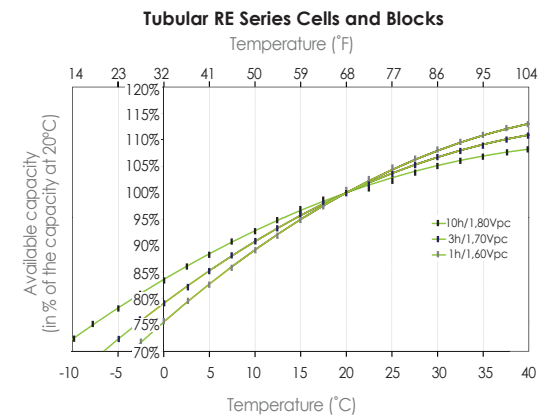

Float Voltage Setting vs. Operating Temperature

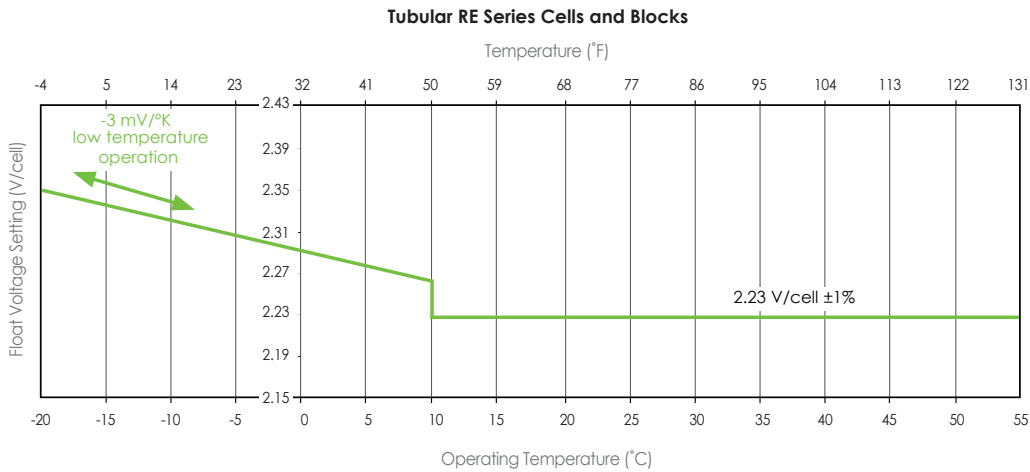

Number of Cycles vs. DOD

