

D1255S

Float AGM Battery Block

Discover® AGM Series VRLA Industrial Batteries provide superior high integrity and reliability for commercial, industrial, and private applications. The maintenance-free Valve Regulated Lead Acid (VRLA) construction make Discover® Standard AGM Series Batteries the definitive choice for broadband and CableTV (CATV), Uninterruptible Power Supplies (UPS), telecommunications, and electronics and security applications.

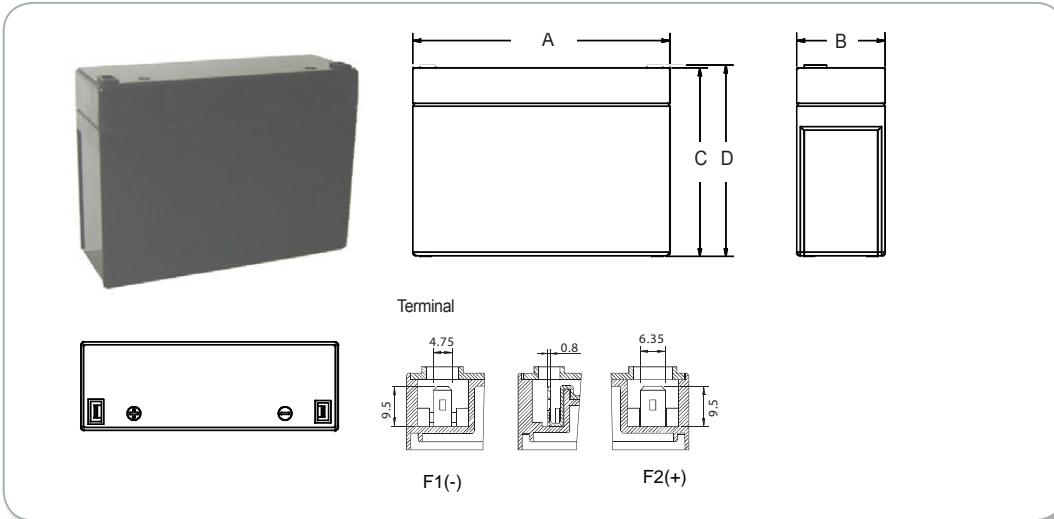

Mechanical Specifications

Industry Reference	-	
Length [A]	5.51 in	140 mm
Width [B]	1.89 in	48 mm
Height [C]	4.02 in	102 mm
Total Height [D]	4.09 in	104 mm
Weight	3.97 lbs	1.8 kgs
Terminal (Opt'l)	F1(-) F2(+)	
Terminal Torque (NM)	-	
Cells	6 Cell	

Electrical Specifications

Volts	12 V
RINT	30 mOhms
Short Circuit (68°F / 20°C)	-
20 HR	5.5 Ah
10 HR	5.2 Ah
5 HR	4.8 Ah
1 HR	3.6 Ah
15 MIN	-
Standard Charge	50°F / -10°C to 122°F / 50°C
Standard Discharge	-4°F / -20°C to 122°F / 50°C
Maximum Discharge**	-40°F / -40°C to 140°F / 60°C

CAUTION:** Extra considerations must be given to depths of discharge, operating voltages and currents when designing systems for use at maximum temperatures.

Discharge Constant Current (Amperes at 77°F / 25°C)

End Point V/C	5 MIN	10 MIN	15 MIN	30 MIN	1 HR	3 HR	5 HR	10 HR	20 HR
1.60V	25.1	16.0	11.5	6.5	3.6	1.54	1.03	0.54	0.285
1.65V	24.1	15.3	11.2	6.28	0.51	0.215	0.140	0.078	0.041
1.70V	23.0	14.6	10.8	6.06	3.4	1.45	0.99	0.53	0.280
1.75V	21.9	13.9	10.4	5.84	3.30	1.40	0.96	0.52	0.275
1.80V	20.6	14.1	10	5.6	3.1	1.35	0.92	0.5	0.265

Discharge Constant Power (Watts at 77°F / 25°C)

End Point V/C	5 MIN	10 MIN	15 MIN	30 MIN	45 MIN	1 HR	2 HR	3 HR	5 HR
1.60V	43.5	28.0	21.8	12.7	9.5	6.66	4.29	2.92	1.98
1.65V	41.0	26.5	20.7	12.1	9.1	6.42	4.17	2.85	1.95
1.70V	38.5	25.0	19.6	11.5	8.7	6.25	4.03	2.77	1.91
1.75V	36.1	23.5	18.5	10.9	8.2	6.1	3.88	2.69	1.87
1.80V	33.7	22.0	17.4	10.3	7.8	5.9	3.73	2.61	1.83

Updated July 17, 2013

AGM Series Features & Benefits

- Tank formed lead-tin-calcium plates deliver consistent dependable performance and promote long life.
- Maintenance-free technology
- 99% gas recombination for extended life in float applications.
- Multiple terminal, configuration options and carrying handles available with most models.
- Classified as a non-spillable battery and is not restricted for transportation by:
 - Air (IATA/ICAO provision 67)
 - Surface (DOT-CFR-HMR49)
 - Water (per IMDG amendment 27).
- Flame retardant ABS case and cover with UL94 V0 rating available.
- UL924 recognized flame arresting low pressure safety vents available.
- 98% recyclable.
- Up to 12 year design life in float service.

Certifications and Standards

Designed in accordance with and published in compliance with applicable BCI, IEC and BS EN standards, including:

- IEC60896-21/22
- BS EN 60254-1:2005
- AS/NZS 4029.2:2000 BS EN 60254-1:2005 (MOD).

Discover® and its facilities and products are certified to multiple standards:

- ISO, UL, QS, and TUV standards
- ETTS Germany
- Euro Bat classification for Environmental Stewardship Standards.



Contact Us

Discover Energy Corp.
 Suite 880-999 West Broadway
 Vancouver BC V5Z 1K5 Canada
 Tel: 604.730.2877
 Email: info@discover-energy.com
www.discover-energy.com

Charging

Max Charge / Discharge Currents	Peak (5 seconds)	Peak (10 seconds)	Max Continuous
Charge	1C20Hr	0.75C20Hr	0.25C20Hr
Discharge	15C20Hr	10C20Hr	0.5C20Hr

“Float” or “Stand-By” Service: Hold a constant voltage source of 2.25vpc to 2.30vpc continuously. When held at this voltage, the battery will seek its own current level and maintain itself in a fully charged condition.

Cyclic Application: Limit initial currents to 0.25C20 ampere. Charge until battery voltage (under charge) reaches 2.4 to 2.45vpc. Hold at 2.40 to 2.45vpc until current drops to under 0.01C20 ampere. Battery is fully charged under these conditions, and charger should be disconnected or switched to “float” voltage.

Temperature Coefficient: Adjust Charging Voltage to +/- 0.005vpc/C, 0.003vpc/F from 25°C / 77°F.

Performance Characteristics

